

Jarless-con
Center-opening /Side-opening
Double folding
Permanent Magnetic
VVVF Door Operator

Operation Instructions

Operation Instructions

All rights reserved.

No part of this document, including electronic, mechanical, micro-coping, photocopying, recording or otherwise, may in any form or by any means be reproduced, stored in a retrieval system or transmitted without prior written permission from our company.

All rights reserved, and violators will be prosecuted. The information in this document is subject to change without notice.

Adjustment steps

1 Positioning(This step has been completed before leaving the factory and is not required for the site. It requires repositioning if the motor or the inverter is changed.)

Place the door in the middle(it can't move the hall door), and turn SW2 to ON, SW3 to OFF, then press learn button key. In this case, the car door will move slightly. Positioning will be completed 5 seconds later.

If the car door can't move when positioning, open the door a little then position again.

2 Auto tuning

Place the door in the middle, and turn SW2, SW3 to ON, then press learn button key. In this case, the auto tuning begins. The direction of movement is: closing the door- door closed limit-opening the door- door opened limit - closing the door- door closed limit -no hold torque, the auto tuning finishes.

If the door move towards the direction of opening, turn SW1 to the adverse condition.

There's no arrival signal after reaching the closed or opened limit during auto tuning.

3 Demonstration operation

Turn SW2, SW3 to ON, and then press run button key. In this case, the door will move towards the direction of closing until it reaches the closed limit. Then press run button again to make the door repeat opening and closing.

It'll output arrival signal after reaching the closed or opened limit during demonstration operation, check this signal and determine if the door operator works well. If there is no signal, ask for reasons according to the Failure Diagnosis Method 3.

4 Setting for normal mode

Turn SW 2 to OFF, and the door begins to close until it reaches the closed limit. Wait for the commands of opening or closing from the control system. If the torque is not kept after the door closed in place, ask for reasons according to practical phenomena and failure diagnosis methods are listed in table.

Failure Diagnosis Method

1 The door operator displays no power supply

A: if power switch is turned on

B: measure the voltage between L and N in P5 and confirm it's AC220V.

C: check the back of inverter, and confirm the wire between fuse and switch is not fallen off or loosen.

If there exists no problems above, the inverter is damaged.

2 Judge of Motor damage

Turn the inverter off, and push three-prong of motor out, measure the resistances in every two phases and each phase to the earth with multi meter.

A: resistance errors of every two phases for U、 V、 W in motor $\leq 2\%$

B: resistances of each phase to the earth is infinite.

3 There is no Arrival signal when demonstration operation

A: while the door is opened or closed, observe the status of corresponding arrival light. If it's on, go to B; if not, go to C.

B: Pull P1 out and demonstrate the door operator, then measure the circuits in P1-1 and P1-2, or P1-1 and P1-3. If the circuits is normal, then the transducer is normal and the signal from the control system is

wrong(problems in wirings of control cabinet or parameters setting).If not, the transducer is damaged.

C: The value of door width gain from auto tuning may be too large and is not got over when it reaches the opened limit. Check DR half range in 3311,if it's half opening door, this value will be half of actual door width added to 50mm.If it is side opening door, this value will be actual door width added to 50mm.If this value gain from auto tuning is different from calculated largely, change this value manually.

4 No hold torque in control system mode

A: Control system mode(run command source in menu M3311 ,or set the value of F 0-2 as 4),this value is set before leaving factory.

B: The door operator will close the door until closed limit and the torque is kept after adjusted in control system mode. The closing signal is required during this process.(Closing the door for the first time when power is turned on after turned off requires closing signal),the closing signal can be canceled when reaching door closed limit and the door operator works well after this.

There is no closing signal in above situations, then there is no torque when reaching door closed limit.

5 The speed is slow or the door crashes slightly when reaching the closed limit

A: Door couple of M3315 or F4-18 is chosen parameters, closed lower speed curves of synchronous and asynchronous door cutter are different, choose parameters according to actual type of door cutter.

B: Problems are not resolved after choosing door cutter, then it may be curves parameters changed and we can initialize parameters to retest. Procedures as follow:

Turn SW2 to ON, SW3 to OFF, then press run button key for 3 seconds, opened and closed arriving signal lights twinkles 3 times, and initialization is complete. Adjust it again according to adjustment steps after initialization again(no positioning).

6 Vibrating when door operator running

A: pull out the motor plug, and judge if motor is damaged according to failure diagnosis method 2.

B: change the first 4 parameters in menu M3312 (or F1), that is PI, to 1000、800、1000、800.

Instruction of Panel operation

Motor positive &negative	Adjustment mode	leaning door width	memory of trouble spot	function	
				Run button	Learn button
SW1	SW2	SW3	SW4	Run button	Learn button
*	ON	ON	OFF	Demonstration operation	Auto tuning
*	ON	OFF	OFF	Press for 3 seconds, initialized into "0 asynchronous door cutter parameters "	positioning
*	OFF	ON	OFF	Control cabinet mode	
*	OFF	OFF	OFF		

*	ON	ON	ON	Press for 3 seconds, initialized into "2 car door lock synchronous door cutter "	Auto tuning
*	ON	OFF	ON	Press for 3 seconds, initialized into "1 synchronous door cutter parameters "	positioning
*	OFF	ON	ON	Control cabinet mode	
*	OFF	OFF	ON		

Parameters list

Function No.	Name	Setting range	Default
Monitoring parameter group (server menu 311)			
Monitoring parameter			
0	Software version		
1	Operation frequency	0~50.00	※
2	Motor rotation speed		※
3	Rotor position	0~359.9	※
4	Given velocity		※
5	Given output voltage	0~900V	※
6	Given torque current	1.0—> rated torque	※
7	Output current	0~999.9A	※
8	Upper digits of run count		※
9	Lower digits of run count		※
10	DC busbar voltage	9999v	※
11	Encoder position	0~65536	※
12	UVW position	00	※
13	Current position	00000	※
14	INPUT 1		※
15	INPUT 2		※
16	Open door input		※
17	Close door input		※
18	Stop		※
F0 (server menu 3311)			
Field adjustment parameter Field Adjust) EEPROM			
F0-0	Obstruction contact memory function	0: disabled 1: enabled	无效
F0-1	Running direction reverse	0,1	0
F0-2	RUN command source	0~5	3
F0-3	Door range	0~65535	■
F0-4	Running distance at low speed of opened door arrival	0~100	5
F0-5	Open Startup unlock speed	5~100mm/s	45/60
F0-6	Open Startup unlock distance	0~30.0%	3.0/5.0
F0-7	Open Acceleration speed	10~2048mm/s/s	1000
F0-8	Open Acceleration fillet	10~2048mm/s/s/s	1000
F0-9	Open Deceleration speed	10~2048mm/s/s	800
F0-10	Open Deceleration fillet	10~2048mm/s/s/s	800
F0-11	Close Arrival speed	5~100mm/s	15/30
F0-12	Running distance at low speed of closed door arrival	5~100	15/30

Function No.	Name	Setting range	Default
F0-13	Close Acceleration speed	10~2048mm/s/s	800
F0-14	Close Acceleration fillet	10~2048mm/s/s/s	800
F0-15	Close Deceleration speed	10~2048mm/s/s	600
F0-16	Close Deceleration fillet	10~2048mm/s/s/s	600
F0-17	Close Startup unlock speed	5~150mm/s	35
F0-18	Close Startup unlock distance	0 ~ 30.0% relay vibration resistance	0
F0-19	Password	0~9999	8888
F1 (server menu 3312) Regulator parameter Regulator)			
F1-0	Proportion gain 1 (high speed)	0~10000	1000
F1-1	Integration gain 1 (high speed)	0~10000	800
F1-2	Proportion gain 2 (low speed)	0~10000	1000
F1-3	Integration gain 2 (low speed)	0~10000	800
F1-4	PI transferring threshold value	0~100	5
F1-5	PI transferring band width	0~100	5
F1-6	Speed feedback filter	0~66 (high and low)	33
F1-7	Given proportional part filter of the torque reference	0~3	0
F1-8	Motor overspeed	1.00~2.00 1.0: Rated RPM	1.25
F1-9	Control method	0:VF 1: Asynchronous motor closed loop 2: Synchronous motor	2
F1-10	Feedback speed calculation	0: High and low levels are different 1: High speed agrees	1
F1-11	Current loop KP	0~9999	512
F1-12	Current loop KI	0~9999	150
F1-13	Electric torque limit (open door)	0.00~2.50	2.50
F1-14	Braking torque limit (open door)	0.00~2.50	2.50
F1-15	Electric torque limit (close door)	0.00~2.50	2.50
F1-16	Braking torque limit (close door)	0.00~2.50	2.50
F1-17	Motor overload protection factor	0.1~2.0	1.2
F1-18	PVT protection sensitivity factor	0~10 0: disable The larger the value is, the lower the sensitivity is.	03
F2 (server menu 3313) Motor parameter Motor Parameters)			
F2-0	Motor power	0.1~999.9 W	43.5/94.3
F2-1	Number of poles	2~100	008
F2-2	Motor rated rotation speed	1~9999	0180
F2-3	Motor rated frequency	1.00Hz~99.99Hz	12.00
F2-4	Motor rated voltage	0~999V	100/125
F2-5	Rated current	1.0~999.9	000.8/1.2
F2-6	Sheaved	10~10000mm	00045
F2-7	Gear ratio	1.0~100.0	001.0
F2-8	Rope	1~6	1
F2-9	Magnetic pole original angle	0~65535	■
F2-10	Stator resistor	0.000~9.999 ohm	7.730/2.790
F2-11	Stator inductance	0.0~999.9mH	357.0/252.4
F2-12	Rotor resistor	0.000~9.999 ohm	5.230/1.820
F2-13	Rotor inductance	0.0~999.9mH	357.0/252.4
F2-14	Mutual inductance	0.0~999.9mH	325.0/240.6
F2-15	No-load current	0.0~999.9A	001.0/2.7
F3 (server menu 3314)			

Function No.	Name	Setting range	Default
Drive parameter Drive Scaling Parameters)			
F3-0	Drive No.	0~100	000
F3-1	Rated voltage	0~1000	0220
F3-2	Rated current	0.0~999.9	002.5
F3-3	Current adjusting coefficient	0.000~2.000	1.00
F3-4	Voltage adjusting coefficient	0.000~2.000	1.050
F3-5	Current limit (over current)	0.0~999.9	005.0
F3-6	Busbar overvoltage point	0.00~2.00	1.4
F3-7	Busbar under voltage point	0.00~1.00	0.60
F3-8	Input voltage coefficient	0.00~2.00	1.00
F3-9	Brake voltage	0.00~1.00 1.00:1000V	0.35
F3-10	Dead time	2~20	03
F3-11	PWM compensation	0.00~2.00	1.00
F3-12	Overshoot factor	0~100	100
F3-13	Carrier frequency	0~12 KHz	12
F3-14	Running time (hour)	0~65535 H should be saved with power down	※
F3-15	Running time (minute)	0~59 MIN should be saved with power down	※
F4 (server menu 3315) Enhanced parameter Enhanced Parameters)			
F4-0	Open/close operation hold time	0~99.9s 0: keep continuous operation Others: stop when the time is up	00.0
F4-1	Power on operation speed	10~100mm/s	0050
F4-2	Door range detection speed	10~100mm/s	0050
F4-3	Close arrival respond time	200~3000ms	1000
F4-4	Open arrival respond time	500~3000ms Hold torque after arrival	800
F4-5	Arrival signal setting	0: with open arrival and close arrival 1: without open arrival but close arrival 2: without open arrival or close arrival	1
F4-6	Open Hold torque	0~200.0%	100.0%
F4-7	Close Hold torque	0~200.0%	60.0%
F4-8	Baffle detection identification time	0~999ms 0: No function	200
F4-9	Baffle torque at high speed	0~200.0% Baffle torque during acceleration	180.0%
F4-10	Close Retarding torque at constant speed	0~200.0% Retarding torque for when ACC = 0	160.0%
F4-11	Baffle torque at low speed	0~200.0% Baffle torque during deceleration	140.0%
F4-12	RY1 function selection	0: open arrival signal (switch or pulse) 1: close arrival signal (switch or pulse) 2: fault output 3: baffle detection output 4: open door output 5: close door output 6: limited open arrival signal 7: limited close arrival signal	0
F4-13	RY2 function selection		1
F4-14	RY3 function selection		2

Function No.	Name	Setting range	Default
F4-15	Open Arrival position	0~1000mm	10
F4-16	Open Speed	0~1000mm/s	0508
F4-17	Open Arrival speed	5~100mm/s	020
F4-18	Door cutter selection	0: Asynchronous door cutter 1: Synchronous door cutter	0
F4-19	Close Arrival position	0~1000mm	5
F4-20	Close Speed	0~1000mm/s	508
F4-21	Reverse open door Deceleration speed	500~9999mm/s/s	5000
F4-22	Reverse open door Deceleration fillet	500~9999mm/s/s/s	5000
F4-23	Demonstration door open hold time	0~999.9s	003.0
F4-24	Demonstration door close hold time	0~999.9s	003.0
F4-25	Manual acceleration	10~2048mm/s ²	0300
F4-26	Manual deceleration	10~2048mm/s ²	0500
F4-27	Manual speed	0~999mm/s	0050
F4-28	Master and slave status setting	0: Master status. Reopening door is possible 1: Slave status. Reopening door is impossible	0
F4-29	Empty	0	00000
F5 (server menu 3316) (VF parameter)			
F5-0	VF mode	0: Linear 1: Square	0
F5-1	Torque boost	0~50.0%	20.0%
F5-2	Automatic torque compensation limit	0~100%	000
F5-3	Baffle identification frequency ratio (at high speed)	0~100.0%	070.0
F5-4	Baffle identification frequency ratio (at low speed)	0~100.0%	050.0
F5-5	Baffle identification switch frequency	0~99.99HZ	00.50
F5-6	Baffle identification time	0~5000MS	0100



Checking fault

Check the fault code (F6) with the operator. See the following table for common fault related information (code of common fault):

Operator serial No.	Name of correspondent fault	Possible cause	Solution
1	BASE FAULT	1, Transducer has foreign objects dropping into it 2, Any two of the three phases of the motor is short circuit	1, Clear away the foreign objects 2, Check motor power line
4	PVT lost	1, Encoder circuit of transducer is abnormal 2, Connection wire of encoder is disconnected or short circuit	1, Replace transducer 2, Check encoder connecting wire

5	MOTOR OVERLOAD	1, Something suffocates the process of opening and closing door 2, Motor lacks phase during running of door operator	1, Check for foreign objects or mechanical blockage 2, Check motor power line
7	DC link OVT	1, Input voltage is too high 2, Any one of the three phases of motor is short connected to ground	1, Check input power supply voltage 2, Check motor power line
8	POWER LOST	Input power supply is low	Check the input power supply, it should be AC 220 V±20%

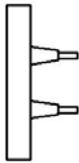
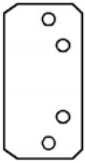
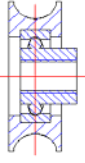
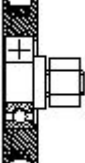
Main parts list

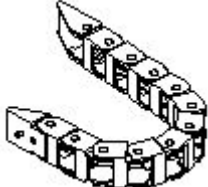
• spare part list		
Name	Drawing no. of parts	sketch
contact switch-plug	XTA4386ABB001	
contact switch-socket	XTA4386ABA001	
Hanging board adjusting roller	XTA3117AHF001	
Hanging board roller- D56mm	XTA3117AHE001	
Synchronous belt	XTB4215AAH- - - (length is needed when buying it)	
Wire guard chain	XTA4284AEY- - - (length is needed when buying it)	

-
- 以上为电气调试说明
 - 电气调试说明书留有一部分空白，做为封面，印上“Jarless-Con 中文调试说明书”字样
 - 册子大小为 A3, 分 4 列，每部分下面用页码标识
 - 制作完成后每列折起来，最后再从中间折起来，封面面向上
 - 册子制作完成后，用简易透明袋装起来
 - 客户若有 LOGO 需求，在封面标识
 - 以下为机械调试说明

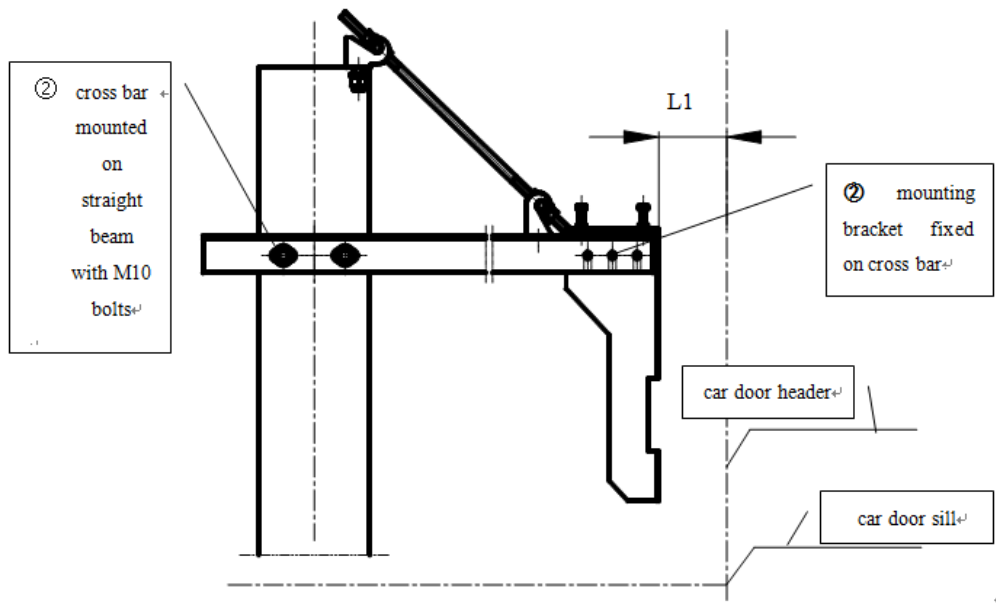

fig.3 Installation of the straight beam of door operator

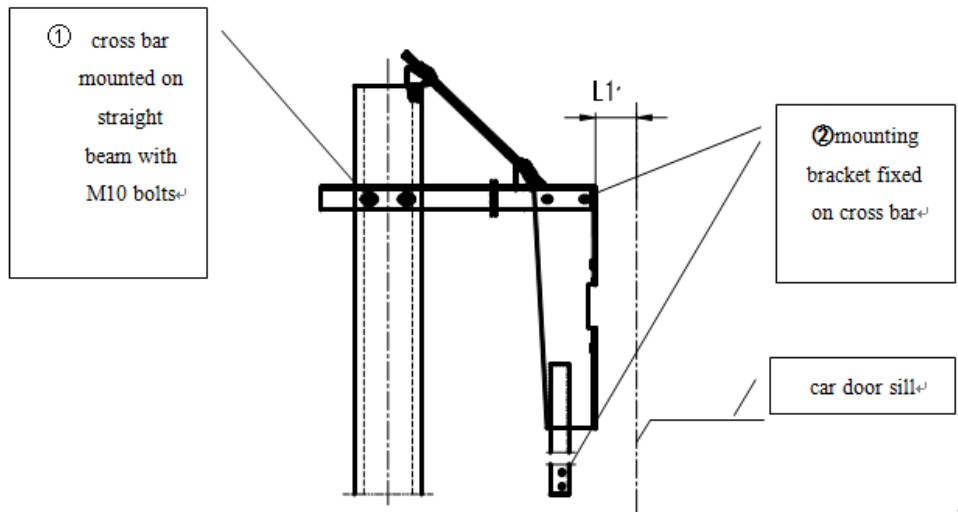

fig.4 Installation illustration of upright of door operator

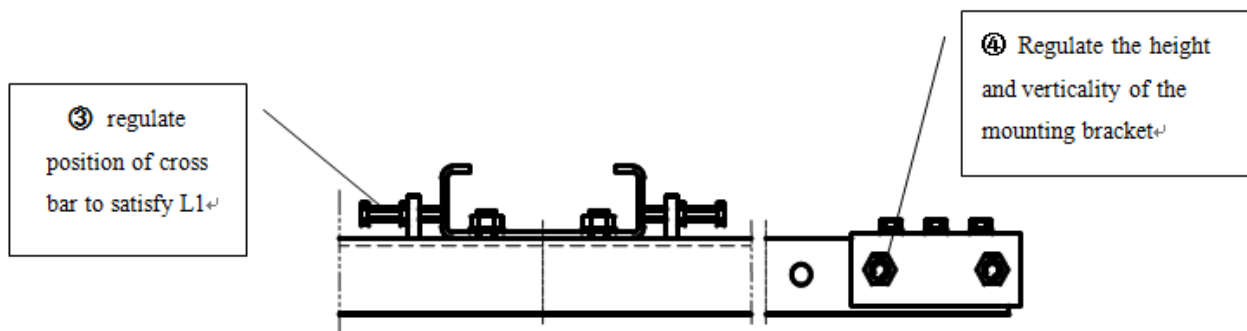

fig.5

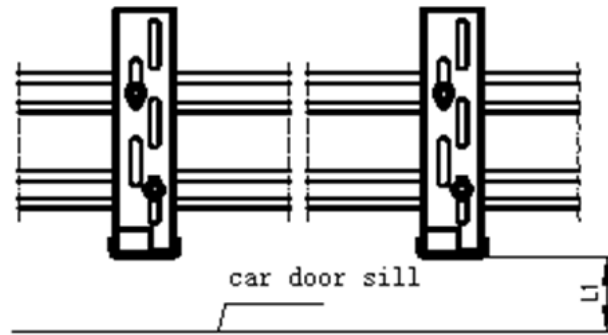

fig.6 Installation illustration of car roof of door operator

4 Install the door operator on the mounting brackets

- ① The door operator is connected to the mounting bracket, pre-tighten the nut on the mounting bracket.
- ② Adjust the height and levelness of door operator, The distance from the surface of the hanging board to the surface of the floor.
- ③ Adjust the center of the door operator, and make it coincide with door center.
- ④ Tighten the nut on the door operator.

5 Hang the door plate on the door operator

- ① The door slider in the plastic bag is mounted to the door plate.
- ② Connect the door plate to the hang board and tighten the bolts.
- ③ Adjust the the verticality of the hang board. If the hanging board is inclined, the plug can be inserted into the connecting point of the hanging board and the door plate.
- ④ Adjust the clearance of the lower roller of the hanging board and the rail to 0.1~0.3 mm
- ⑤ Adjust the verticality of the two plates, and the distances between the door plate and the front wall of the car and the sill of the car.

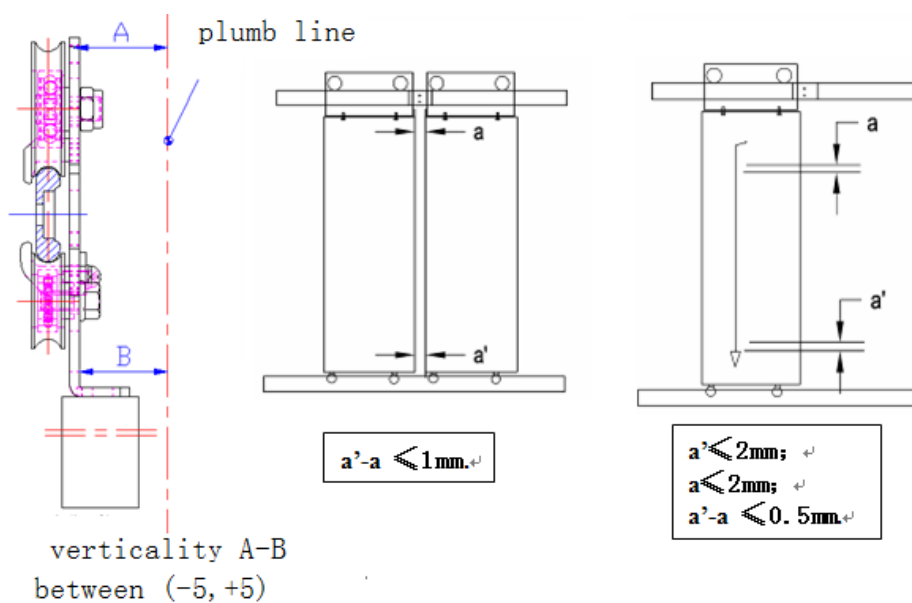

fig.7

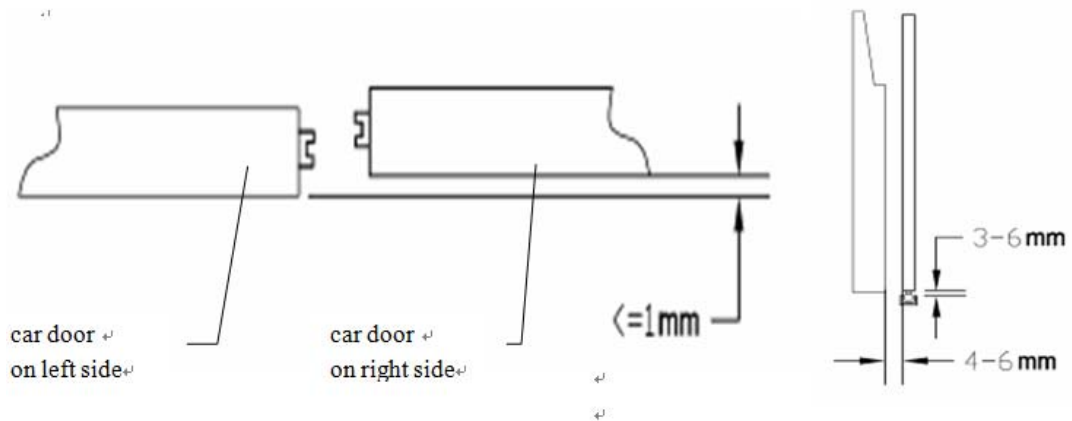

fig.8

6 Install door cutter on door operator

(Attention: The door cutter is assembled when leaving the factory, and this tips is needed if it requires)

a、Installation of the synchronous door cutter

- ① Install the door cutter on the hang board, the bolts are installed in middle of waist holes of door cutter base.
- ② Measure the distance from forefront of door cutter to forefront of hall door sill, this value should be 8~10mm. Add shims between bottom plate of door cutter and door plate according to actual size until this value meets requirement.
- ③ Adjust the verticality of door cutter and make it vertical.
- ④ Tighten the bolts for mounting the door cutter
- ⑤ Adjust position of waist holes connecting synchronous door cutter of integrated car door lock and hang plate, until the door cutter blade is vertical.
- ⑥ Adjust position of waist holes connecting the hook and the door operator to ensure that the hook and door operator work smoothly when opening or closing the door.

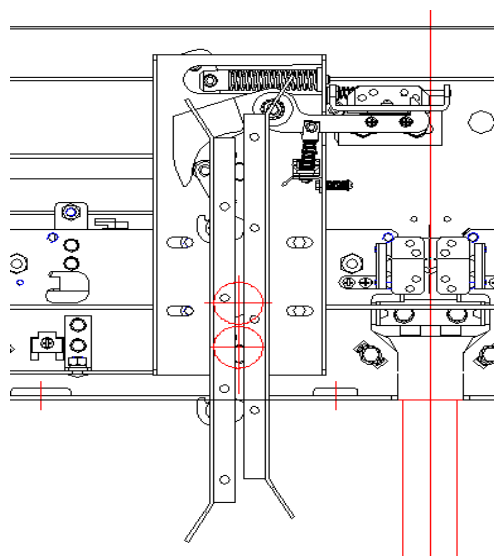

fig.9

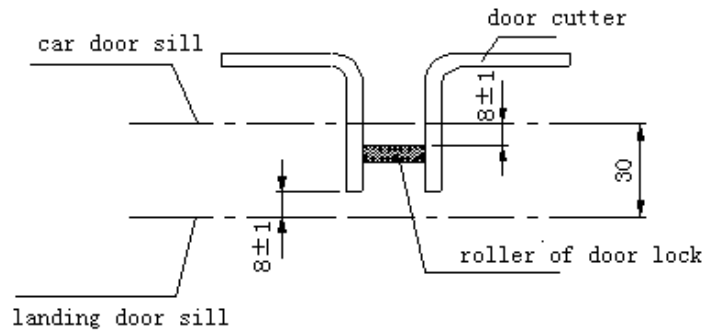
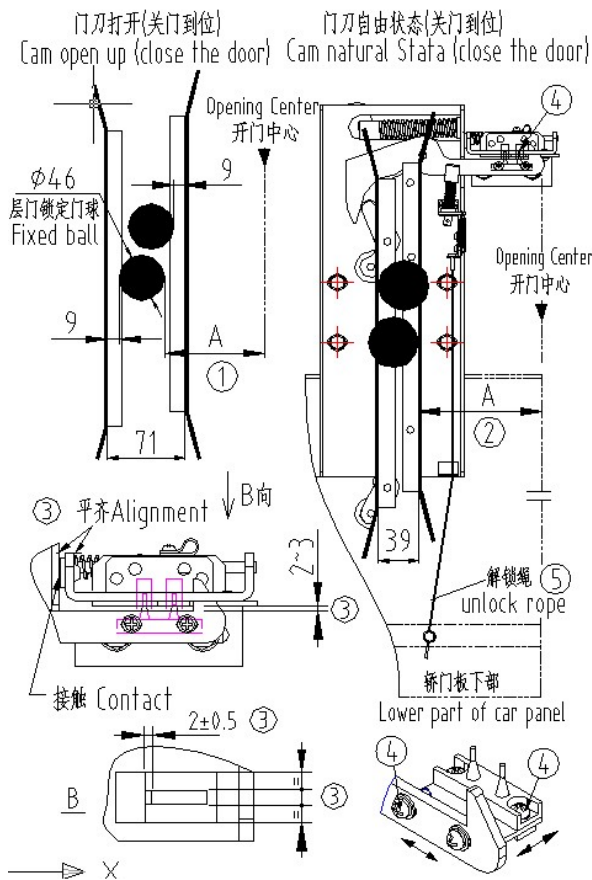

fig.10

b、 Structure sketch of the synchronous door cutter



- ① 确定层门定门球距开门中心位置A
Determine the distance between the door fixed ball and the position A in the center of the door
- ② 门刀自由状态下，调整右侧刀片至A位置
Under the free state of the door knife, adjust the right blade to A position
- ③ 调整门刀附件顶部与刻度平齐，确保钩子间隙2~3mm
Adjust the top of the door knife accessories to make it flush with the scale, ensure hook clearance 2~3mm.
- ④ 调整门刀的垂直度及插针位置，确保插针插入插座中间。
Adjust the verticality of the door knife and the location of the pin to ensure the pin has been inserted into the middle of the socket
- ⑤ 将解锁钢丝绳固定于轿门板下部
Fixed the unlock wire rope to the lower part of the car panel

fig.11

7 Installation of rod of door operator

- ① The hooks are respectively arranged on the upper beam and cross bar. If the reinforcing rod is configured, and another hook are need to be installed on the door operator and the bar respectively.
- ② The pull rod (long) is installed on the two hooks of upper beam and cross bar, adjust the tension degree and ensure that the pull rod is just tightened and can't pull up the front section of the cross bar. If the reinforcing rod is configured, install reinforcing rod on the two hooks of upper beam and cross bar, then adjust the tension degree of reinforcing rod
- ③ Check the verticality of door, gap of the door panel and the front wall after pull rod assembly is installed, if there is a change, trim pull rod until the verticality and the gap meet the requirements.

8 Wiring of door protection

a. Wiring of the safety edge

When the safety edge is fitted, its wiring is in accordance with figure 12. When the light curtain is fitted, its wiring is in accordance with figure 13. The cable should be tied securely with tape in reverse pulling fashion on the car door and connected to the control circuit through the drag chain by means of the bracket of drag chain.

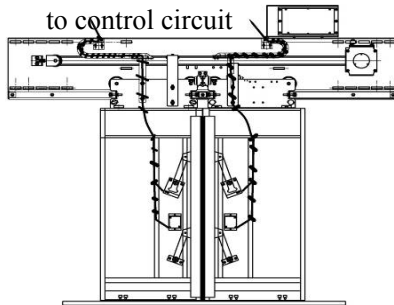

fig.12

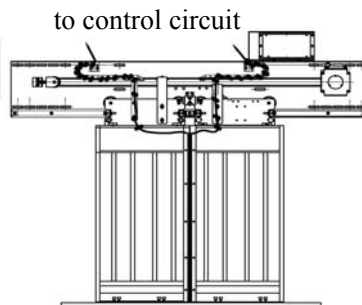

fig.13

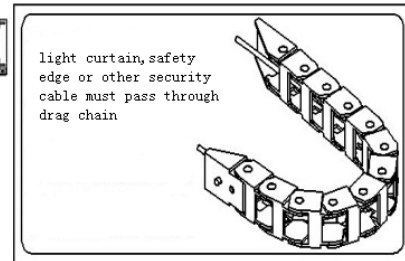

fig.14

b. Installation requirements of the light curtain

1. The surface at the bottom of the light curtain should be flush with that of the fixing bracket, and the distance between the surface at the bottom of the light curtain and the surface at the bottom of the car door board should be 10 mm at least; The two light curtains should be 10 to 20 mm apart from each other when the door is closed; All the mounting holes of the light curtain should be fixed on the door leaves.
2. The light curtain line should be fixed securely along the strengthening rib of the door board with tape in reverse pulling fashion, and then it is connected to the junction box of light-beam curtain on the car roof.
3. After the light curtain is installed, it should be grounded. The ground line is connected to the car door with bolts and is made into a loop connected with the ground line on the car roof.

Care and maintenance

1 Regular maintenance items of door operator

It's necessary to care and maintain the door operator regularly to ensure its reliable running, and maintenance contents are refer to the table below.

NO.	items	contents
1	Door guide shoe	Adjust interval of door guide shoe and sill groove, and observe degree of wear
2	Regulating wheel at bottom of hang	Adjust interval of side wheel at bottom and railway, observe degree of wear wheel
3	Hang wheel	observing running situation of
4	Railway	clear surface of railway, add gear grease and observe degree of wear
5	Synchronous belt	observe and Adjust degree of tightening
6	Steel wire rope	observe and Adjust condition of ropes, degree of tightening and compaction degree of clamp
7	Contact switch	observe if switch contacts well and adjust relative position
8	Drag chain	observe condition of chains and if chains are fixed firmly
9	Cable	observe if cable is broken

2 Changed standard of easily damaged parts

Changed standard of easily damaged parts		
NO.	Name	Changed standard
1	Contact switch	plastic shell is broken, spring fingers turn black
2	Door guide shoe	abrasion of door guide shoes is serious, door plate vibrates while running
3	Regulating wheel at bottom of hang board	the rotation is not smooth or worn badly
4	Wheel of Hang board	abrasion of polyurethane is serious, wheel shakes and rotates with a abnormal sound
5	Synchronous belt	synchronous belt is worn badly or has obvious cracks
6	Synchronous pulley	the rotation is not smooth, along with a clear sound and axial shaking
8	Steel wire rope	fluffed or broken
9	Drag chain	chains are broken

3 Determining standard of wastes

1. Plastic deformation occurs on mechanical parts of door operator because of transportation, installation or abnormal failure
2. Abrasion, distortion deformation occurs on mechanical parts of door operator used for a long time and it leads to open or close door abnormally even work with noise, changing easily damaged parts can't meet requirements yet.
3. Controller and motor beyond of life cycles can't replaced with spare parts when it appears failures.